

RF1200 Flake Ice Machine



Model RF1200A
Flake Ice Machine
on B-570 Bin

- Up to 1,186 lbs. (538 kgs.) daily flake ice production.
- High load capacity bearings for enhanced reliability.
- Heavy duty stainless steel cabinet resists corrosion.

Warranty

- 3-year Parts
- 2-year Labor
- Compressor parts for 5 years and labor for 2 years.



ISO 9001:2000
Quality System
Certified

America's #1 Selling Ice Machine

Ice Cube & Flake Machines • Ice Storage Bins • Ice Dispensers



Manitowoc RF1200 Flake Ice Machine

	Model	Ice Shape	Ice Production 24 Hrs.		Power kWh/100 lbs./90°/70°F	Water Usage (100 lbs./45.4 kgs. of Ice)	
			70° Air / 50°F Water	90° Air / 70°F Water		Potable Water	Condenser Water
AIR-COOLED	RF1200A	Flake	1,186 lbs.	864 lbs.	5.63	12 Gal.	N/A
			538 kgs.	392 kgs.		45.4 L	N/A
WATER-COOLED	RF1200 W	Flake	1,204 lbs.	1,004 lbs.	4.11	12 Gal.	103 Gal.
			546 kgs.	455 kgs.		45.4 L	390 L

Ice Machine Electric

208-230/60/1 standard. (230/50/1 also available.)

Minimum circuit ampacity: 15 amps.

Maximum fuse size: 15 amps.

HACR-type circuit breakers can be used in place of fuses.

Specifications

BTU Per Hour:

Air: 14,000 (average)

Water: 1,500 (average)

Compressor:

Nominal rating: 1.5 HP

Refrigerant: R-404A

Operating Limits:

- Ambient Temperature Range
Air- and Water-cooled:
50°-110°F (10°-43°C)
- Water Temperature Range:
37°-90°F (3°-32°C)
- Water Pressure Ice Maker
Water In:
Min. 14 psi (96.5 kPa)
Max. 80 psi (551.6 kPa)
- Condenser Inlet Water In:
(Water-cooled only)
Min 20 psi (137.9 kPa)
Max 150 psi (1034.2 kPa)
Water Condenser not for
sea water applications.



Standard Equipment

K-00404 30" B-Style Bin Adapter

Accessories

K-00405 48" B Style Bin Adapter*

*adapter not for use with Large Capacity Bins.

Air Flow Overhead View

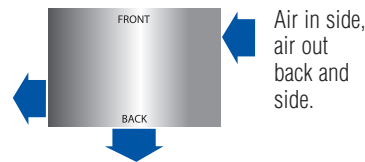

Air in side,
air out
back and
side.

Space-Saving Designs

RF1200
B-570



Height	77.56" 197.00 cm
Width	30.00" 76.20 cm
Depth	34.00" 86.36 cm
Bin Storage	430 lbs. 195 kgs.

Height includes adjustable bin legs 6.00" to 7.00", (15.24 to 17.78 cm) set at 6.00" (15.24 cm).

Ice Shape

Combination of small and large bits of ice for presentation and cooling applications.



Ice shown actual size

RF1200 on B-570 Storage Bin

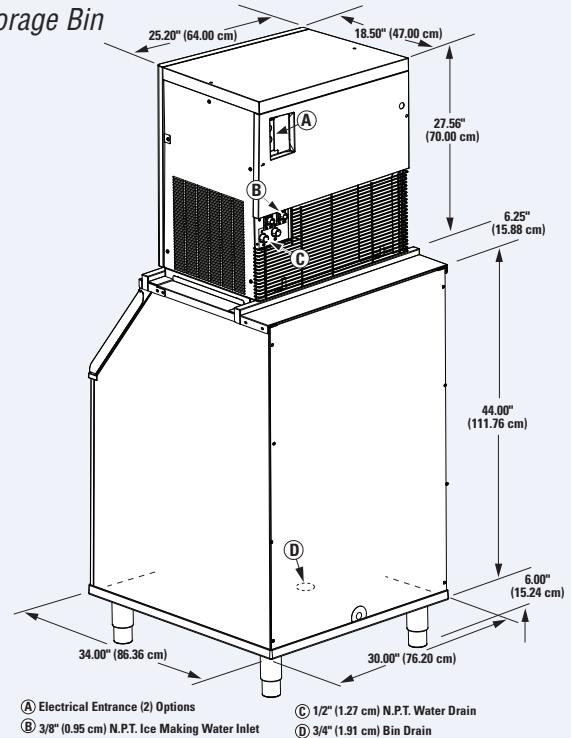

Installation Note - Minimum installation clearance:
 Top/sides: 8" (20.32 cm), back: 5" (12.70 cm).



We are committed to protecting the environment and its resources. For up-to-date product data always view an electronic version on our web site.



MANITOWOC ICE
 2110 South 26th Street, P.O. Box 1720
 Manitowoc, WI 54221-1720, USA
 Ph: 920-682-0161 • Fax: 920-683-7589
 Visit us online at www.manitowocice.com

