

S-Series 1800 Ice Cube Machine



SD-1802A Ice Machine
on B-970 Bin

- SANITATION**
We've made it simple to clean
- SAVINGS**
The perfect balance of power and efficiency
- SOUND**
Designed to run whisper-quiet
- SERVICEABILITY**
Easy access means less downtime

- Up to 1,890 lbs. (857 kgs.) daily ice production
- Removeable water distribution tube requires no tools to remove
- Food zone designed with soft rounded corners
- Patented cleaning and sanitizing technology
- Select components compounded with AlphaSan® antimicrobial
- Patented ice harvest technology reduces energy requirements
- Hinged front door for easy access
- R-404A CFC-free refrigerant
- Warranty
5-year parts and 5-year labor coverage on ice machine evaporator
5-year parts and 3-year labor coverage on ice machine compressor
3-year parts-and-labor coverage on all other ice machine, dispenser, and storage bin components



ISO 9001:2000
Quality System
Certified

America's #1 Selling Ice Machine

Ice Cube & Flake Machines • Ice Storage Bins • Ice Dispensers



Manitowoc S-Series 1800

Model	Ice Shape	Ice Production 24 hours		Power Usage kWh/100 lbs. @ 90°F Air/70°F F				Water Usage/100 lbs. 45.4 kgs. of Ice		ENERGY STAR®
		70°F Air/ 50°F Water	90°F Air/ 70°F Water	1 Ph	CEE Tier	3 Ph	CEE Tier	Potable Water	CEE Tier	
SD-1802A	dice	1830 lbs.	1460 lbs.	4.95	1	4.85	1	20.0 gal.	3	
		830 kgs.	652 kgs.					75.7 L.		
SY-1804A	half-dice	1890 lbs.	1520 lbs.	4.80	1	4.85	1	20.0 gal.	3	
		857 kgs.	689 kgs.					75.7 L.		
SD-1803W	dice	1880 lbs.	1670 lbs.	3.65	2	3.65	2	20.0 gal.	3	NA
		853 kgs.	757 kgs.					75.7 L.		
SY-1805W	half-dice	1890 lbs.	1750 lbs.	3.65	2	3.60	2	20.0 gal.	3	NA
		857 kgs.	794 kgs.					75.7 L.		
Water-cooled Condenser Water Usage /100 lbs./45.4 kgs. of Ice: 141 gal./533.7 L										
SD-1892N	dice	1750 lbs.	1510 lbs.	4.59	2	4.51	2	20.0 gal.	3	★
		794 kgs.	685 kgs.					75.7 L.		
SY-1894N	half-dice	1770 lbs.	1540 lbs.	4.59	2	4.55	2	20.0 gal.	3	★
		803 kgs.	699 kgs.					75.7 L.		

Order ice storage bin separately. "A" or "W" following model number indicates "Air" or "Water" condensing unit. Ice storage bin and JC-1395A remote condenser must be ordered separately. Consult remote condenser specification sheet for details. To order 3 phase add "3" suffix to model # (SD-1802A3).

1 2 3 Consortium for Energy Efficiency (CEE) is a North American non-profit organization that promotes energy-efficient products, technologies and services; also the principal entity for the development of ice maker efficiency standards.

 Certified in Accordance with ARI Automatic Commercial Ice-Cube Machines (Batch-Type) Certification Program, which is based on ARI Standard 810

Ice Machine Electric

208-230/60/1 standard. (208-230/60/3 and 230/50/1 also available.)

Min. circuit ampacity: Air-cooled: 23.8 1ph 15.4 3ph
 Water-cooled: 22.4 1ph 14.0 3ph
 Remote-cooled: 23.4 1ph 15.0 3ph

Max. fuse size: Air-cooled, Water-cooled, Remote: 40 amps 1ph 60Hz
 25 amps 3ph 60Hz
 30 amps 1ph 50Hz

HACR-type circuit breakers can be used in place of fuses.

Specifications

BTU Per Hour:

30,000 (average) 35,000 (peak)

Compressor: Nominal rating: 3 HP

Cupra-Nickel Condenser:

(Water-cooled models) Adds protection from corrosive water elements.

Operating Limits:

Ambient Temperature Range:

Air and water-cooled: 35° to 110°F (1.67° to 43.3°C)
 Remote: -20° to 120°F (-29° to 49°C)

Water Temperature Range:

35° to 90°F (1.67° to 32.2°C)

Water Pressure Ice Maker

Water In: Min. 20 psi (137.9 kPa)
 Max. 80 psi (551.1 kPa)

Condenser Inlet Water In:

(Water-cooled only)
 Min. 20 psi (137.9 kPa)
 Max. 150 psi (1,034.2 kPa)

Air Flow Top View

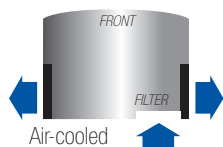

AuCS@SI Accessory



Automatic Cleaning System purchased factory installed in the machine or as an option for field retrofit.

2 Cube Sizes Available



Half Dice
 3/8" x 1 1/8" x 7/8"
 (.95 x 2.86 x 2.22 cm)



Dice
 7/8" x 7/8" x 7/8"
 (2.22 x 2.22 x 2.22 cm)

We are committed to protecting the environment and its resources. For up-to-date product data always view an electronic version on our web site.



Mixed Sources

Product group from well-managed forests, controlled sources and recycled wood or fiber.
 www.fsc.org Cert no. SW-COC-001886
 © 1996 Forest Stewardship Council



24-HOUR ICE PRODUCTION						
Air Temp.	Dice			Half Dice		
	Water Temperature			Water Temperature		
F°	50°F	70°F	90°F	50°F	70°F	90°F
C°	10°C	21°C	32°C	10°C	21°C	32°C
70°F	1830	1700	1580	1890	1720	1620
21°C	830	771	717	857	780	735
80°F	1700	1570	1450	1820	1650	1550
27°C	771	712	658	826	748	703
90°F	1590	1460	1340	1690	1520	1420
32°C	721	662	608	767	689	644
70°F	1880	1710	1550	1890	1790	1570
21°C	853	776	703	857	812	712
80°F	1850	1680	1520	1860	1760	1540
27°C	839	762	689	844	798	699
90°F	1840	1670	1510	1850	1750	1530
32°C	835	757	685	839	794	694
70°F	1750	1610	1510	1770	1650	1550
21°C	794	730	685	803	748	703
80°F	1730	1590	1490	1720	1600	1500
27°C	785	721	676	780	726	680
90°F	1650	1510	1410	1630	1540	1440
32°C	748	685	640	739	699	653

Space-Saving Designs

S-1800
B-970



Height 79.50"
201.90 cm
 Width 48.00"
121.92 cm
 Depth 34.00"
86.30 cm
 Bin Storage 710 lbs.
322.2 kgs.

Height includes adjustable bin legs 6.00" to 7.00" (15.24 to 17.78 cm) set at 6.00" (15.24 cm). For comparison purposes multiply ARI capacity by 1.3 (30%) to arrive at approximate "Application Rating Capacity."

S-1800 on B-970 Storage Bin

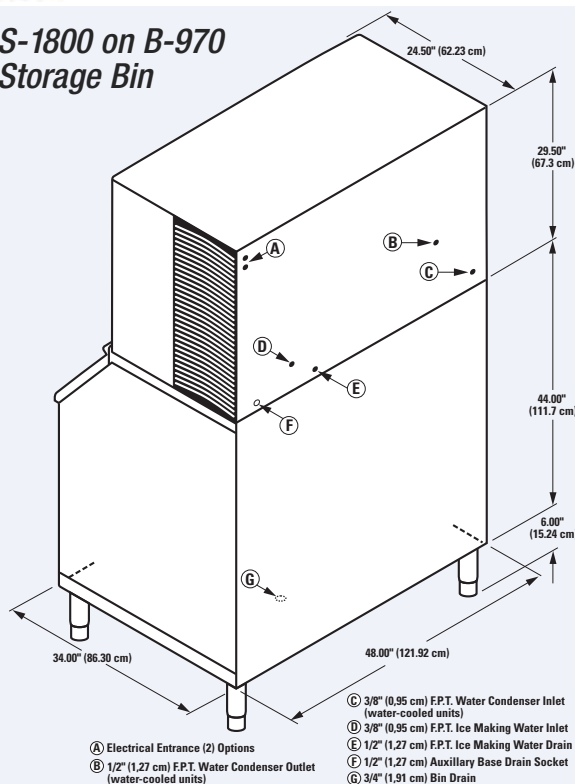

©2008 Manitowoc 6/09. Continuing product improvement may necessitate change of specifications without notice.

3123D

Installation Note - Minimum installation clearance—
 Water and remote units— Top/sides: 8" (20.32 cm), Back: 5" (12.7 cm).
 Air-cooled units— Top/sides: 24" (60.96 cm), Back: 12" (30.48 cm).



MANITOWOC ICE
 2110 South 26th Street, P.O. Box 1720
 Manitowoc, WI 54221-1720, USA
 Ph: 920-682-0161 • Fax: 920-683-7589
 Visit us online at www.manitowocice.com

