



 **Manitowoc® Koolaire™** 
REACH-IN REFRIGERATORS & FREEZERS
SANDWICH/SALAD UNITS

Manitowoc® Koolaire™

REACH-IN REFRIGERATORS & FREEZERS

KOOLAIRE™

A new name that defines this new series of reach-in refrigerators and freezers. High quality, reliable refrigeration equipment for professional operations. Efficient design, careful material selection, highly skilled employees, and rigorous quality control - including operational testing of each unit - assure the quality of these products. Reach-in for value? Reach-out to Manitowoc Koolaire.



Koolaire presents a different way of circulating air within a refrigerated cabinet. Refrigerated air is not forced into the cabinet, but "directed".

Cold air is directed down one side of the cabinet to force warmer air up the other side of the cabinet and out of the unit. No warm spots, no dead spots. Benefits include uniform temperatures; reduced pull down time; reduced compressor running time, and decreased outside air intrusion.

Specifications page 7

YOUR CHOICE OF DOORS

Solid Doors

Self-closing and fully insulated doors with chrome-plated and self-lubricating cam-lift hinges. Right hinging standard. Left optional. Large recessed handles are easy to grip, even when wearing gloves.



Door perimeters have a built-in, low wattage, anti-condensate heater. Door openings are protected by an impact-resistant, nonconductive PVC breaker strip with no exposed screws or fasteners.

Glass-Doors

Full-view glass-doors are fitted with 2-pane tempered heat reflective glass with low profile frame for greater product visibility. One door has



horizontal 40 watt fluorescent lighting. 2 and 3-door models have vertical lighting arrangement. 90° door hold open device is standard. Chrome-plated pull handles have built-in cylinder locks. Handles are large and easy to grip. Can be removed quickly to facilitate delivery through narrow doorways.

Half-Doors

Half height doors have same construction specifications as solid doors yet offer added flexibility and convenience.



STAINLESS STEEL FRONT

Stainless steel front with anodized aluminum side panels provides a bright, durable surface for long life. Smooth aluminum interior with coved corners makes cleanup fast and easy. Durable stainless steel interior floor resists dents and scratches, protects against acidic corrosion.

WARRANTY

Parts and labor for 2 years - best in the industry. Also includes an additional 3-year (5-year total) parts warranty on the evaporator and compressor.

FRONT-AIR INTAKE DESIGN

Provides better performance efficiencies in high ambient or low-clearance applications. Improves airflow to compressor and condenser coil. Easy to remove and clean front air filter traps dirt, lint, and dust. Quick access for maintaining the refrigeration system improves operating efficiencies.



DOOR HINGE

Cam-lift hinges are chrome-plated and self-lubricating. Hinges also have a safety stop that limits the door opening, preventing over swing.

Interior Features

- 3 epoxy-coated, steel-wire shelves per opening adjust in 1" increments and will not chip, corrode, or rub off. Shelf size: 21.25" x 25.25", Shelf area: 14.90 sq. ft.
- Heavy-duty stainless steel shelf pilasters are adjustable. No tools required to accommodate various size trays and pans.
- Coved-corner construction assures easy clean-up.
- Incandescent lighting is controlled by a light switch concealed in the door hinge which activates automatically when door is opened. Glass door models employ a manual switch.

- Smooth, flat aluminum finish is easy to clean.
- Foamed-in-place polyurethane insulation—2" cabinet walls, 1.5" doors. Provides R-14 insulating efficiency.



Epoxy-Coated Steel Shelves



Heavy-Duty Pilasters



Coved-Corner Construction



- Anti-condensate heater wires around complete perimeter of each door opening are standard for freezers and refrigerators. On refrigerators, customer activates heater strip via convenient on/off switch. No add-on kit necessary. Automatic activation for freezers.
- Stainless steel floor resists dents, scratches, and acidic corrosion.
- Top mounted refrigeration system adds more storage space and stays cleaner.
- Refrigeration system is balanced to maintain 38°F average internal air temperature.

Exterior Features

- Stainless steel doors and front for durable good looks. Not field reversible. Right-hand swing is standard on one-door model.
- 6" diameter casters.
- Keyed door locks.
- 9-foot long, 3-wire power cord with 3-prong ground-type plug. (115/60/1).



- Temperature monitor—easy-to-read, color-coded drum, analog thermometer reading in C° and F°.
- Adjustable temperature control conveniently located behind front panel.
- Refrigeration assembly is housed beneath a removable hatch cover.



- Hot gas evaporator uses heat by-product to eliminate condensation.
- Two-position bumper adjusts degree of door swing.
- Tight, positive-seal, self-closing doors with cam-lift hinges. Self-adjusting door gasket magnetically seals cabinet upon closure.

Options



- Half door refrigerators and freezers.
- Glass door refrigerator.
- Tray slides.
- Additional shelves.
- Left or right door swing.
- 6" to 7" adjustable black legs.



Manitowoc® Koolaire™

UNDERCOUNTER & SANDWICH/SALAD PREP UNITS

CABINET

Stainless steel top, front, doors, and exterior ends. All metal welded construction. All joints and seams closed and sealed. Enclosed rear with removable machine compartment panel, zinc coated exterior steel bottom and rear with coved, sanitary aluminum interior. The unit is supported by

6" minimum height adjustable legs with non-marring feet. Sandwich and salad unit model tops are provided with a foamed-in-place, high impact non-conducting thermobarrier, raised edge breaker frame. Opening fitted with 1/6 size 4" drop high impact plastic salad pans. Openings will accommodate 6" deep inserts (not provided).



DOORS

Self-closing with full face stainless steel exterior and aluminum inner pan. Doors insulated with one shot, closed cell, foamed-in-place polyurethane insulation. Magnetic door gaskets are removable without tools and one piece vinyl keyed into a thermal breaker retainer frame. All door openings have full perimeter minimum-wattage anti-condensate heaters behind the stainless steel fascia to retard condensation. Doors are self-closing with safety stops and stay-open feature. Doors on single section models are factory hinged right (facing cabinet) but are reversible and can be quickly re-hinged without special tools (with additional hardware).



WARRANTY

Two-year parts and labor - best in industry. Also includes an additional 3-year (5-year total) parts warranty on the evaporator and compressor. All units are performance tested on the production line prior to shipping.



SELF-CONTAINED REFRIGERATION

The system is a forced-air with automated defrost, hermetic design with capillary-metering device and automatic thermostat. All models are complete with a removable, energy free automatic condensate evaporator. No floor drain or plumbing connections required.

INTERIOR SHELVES

Two heavy-duty, adjustable removable epoxy coated shelves are furnished for each door section. Adjustable pilasters available as standard on all models.



Features - All Undercounter Models

- Stainless steel fronts, doors, top, and exterior ends. Zinc coated steel exterior bottom and rear.
- Special, extra rigid one-shot high pressure foamed-in-place polyurethane insulation. Average thickness: 2".
- Automatic defrost system.
- Self-closing doors have concealed hinge mechanism.



- One piece door pull, safety stops, and stay open feature.

- Coved-corner construction assures easy clean-up.
- One piece removable magnetic door gasket.

- 6" adjustable legs with non-marring feet.
- 2 epoxy-coated, steel-wire

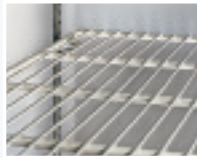

shelves per opening adjust in 1" increments and will not chip, corrode, or rub off.

- Heavy-duty stainless steel shelf pilasters are adjustable. No tools required to accommodate various size trays and pans.
- Full perimeter minimal wattage anti-condensate heaters.
- 6-foot long, 3-wire power cord with 3-prong ground-type plug (115/60/1).



- Doors on the single section models are reversible and can be quickly rehinged without special tools (with additional hardware). Hinged on the right (facing cabinet) standard.
- No floor drain or plumbing connections required.

Sandwich/Salad Prep Units



- Full access, combination stainless steel telescoping box cover and utility shelf.
- 4" deep salad/condiment high impact plastic pans included (1/6 size). Openings will accommodate 6" deep inserts (not provided).
- Tops have foamed-in-place, high impact non-conducting thermobarrier with raised edge breaker frame.
- Interior thermometer standard.
- Removable/reversible synthetic cutting board.



Options

- Stainless steel interior.
- Stainless steel exterior back.
- Door locks; individual cylinder type.
- Swivel casters-
6" load height for 27" models;
3.75" and 6" for 45" and 59" models.

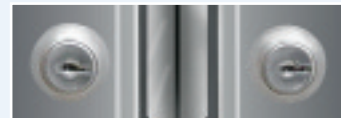

Undercounter Refrigerators & Freezers

REFRIGERATOR* (38°F)

- R-134A refrigerant
- Automatic adjustable thermostat
- Space-saver evaporator with high-humidity, fin coil for extra long life

FREEZER* (0°F)

- R-404A refrigerant
- Defrost system is time initiated, with built-in, auxiliary safety cutoff
- Automatic thermostat and timer
- Stainless steel overhead shelf

*Average internal air temperature

ONE-DOOR MODEL - 27" W

- 7 cubic feet of gross storage capacity
- 7 square feet of shelf area
- 2 heavy-duty, adjustable epoxy coated shelves

TWO-DOOR MODEL - 45" or 59" W

- 12 or 16 cubic feet of gross storage capacity
- 12.74 or 17.2 square feet of shelf area
- 2 heavy-duty, adjustable epoxy coated shelves per door opening

Model	# Doors	Type of Unit	B.T.U per Hour*	Total Amps	Max. Fuse Size	Compressor Size
KR-6E	1	Refrigerator	1,755	6.0	15	1/5 HP
KF-6E	1	Freezer	1,285	8.5	15	1/3 HP
KR-10E	2	Refrigerator	1,755	8.0	15	1/5 HP
KF-10E	2	Freezer	1,285	8.5	15	1/3 HP
KR-15E	2 (59")	Refrigerator	1,755	6.0	15	1/5 HP

*Based on 90°F ambient and 20°F evaporator.

Electric: 115/60/1. (230/50/1 also available, consult factory). Supplied with 6' (1.85 m) long, 3-wire power cord with 3-prong ground-type 5-15 NEMA plug.

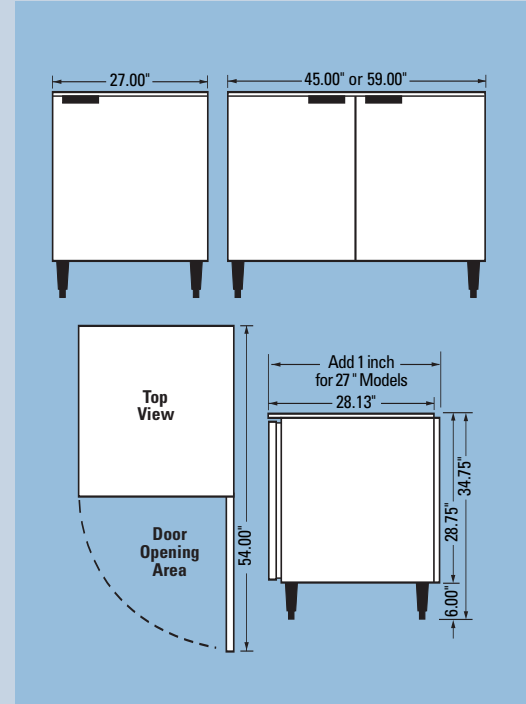

Sandwich/Salad Prep Units

REFRIGERATOR MODELS ONLY (33-41°F)

- R-22 refrigerant
- Automatic defrost
- Full access, combination stainless steel telescoping box cover and utility shelf
- Interior thermometer
- Energy-free automatic condensate evaporator
- Working height 35.50"

ONE-DOOR MODEL - 27" W

- 7 cubic feet of gross storage capacity
- 7 square feet of shelf area
- 2 heavy-duty, adjustable epoxy coated shelves
- 12" full width removable/reversible synthetic cutting board

TWO-DOOR MODEL - 45" W

- 12 cubic feet of gross storage capacity
- 12.74 square feet of shelf area
- 2 heavy-duty, adjustable epoxy coated shelves per door opening
- 8.50" full-width removable/reversible synthetic cutting board

Model	# Doors	# Pans ¹	B.T.U per Hour ²	Total Amps	Max. Fuse Size	Compressor Size
KP-6	1	8	1,755	6.0	15	1/5 HP
KST-27-2	1	12	1,285	8.5	15	1/3 HP
KP-10-12	2	12	1,755	8.0	15	1/5 HP
KST-45-3	2	18	1,285	8.5	15	1/3 HP

¹1/6 size pan. ²Based on 90°F ambient and 20°F evaporator.

Electric: 115/60/1. (230/50/1 also available, consult factory). Supplied with 6' (1.85 m) long, 3-wire power cord with 3-prong ground-type 5-15 NEMA plug.

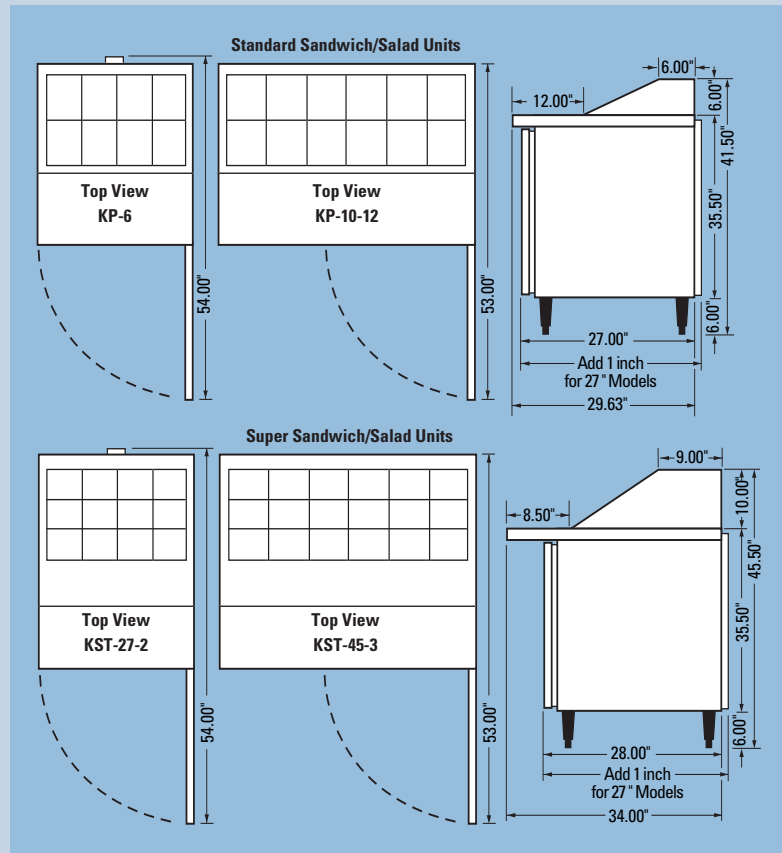

Reach-In Refrigerators & Freezers

REFRIGERATOR (35-40°F)

- R-134A refrigerant.
- Frost-free system eliminates evaporator coil icing or frost build-up.
- Evaporator coil's protective coating resists corrosion from airborne food acids. Assures long life, efficient operation.

FREEZER (0°F)

- R-404A refrigerant.
- Defrost system is time initiated, temperature terminated, and has a fail-safe provision. Preset to defrost the evaporator three times a day.
- Automatic fan delay after defrost cycle prevents air circulation until coil has cooled.

ONE-DOOR MODEL - 27.50" W

- Provides 22.4 cubic feet of gross storage capacity.
- 3 adjustable shelves
- 14.90 sq. ft. shelf area (includes floor area)

Solid Door	Half Door	Type of Unit	B.T.U per Hour	Total Amps	Max. Fuse Size	Compressor Size
KR-1	KR-101	Refrigerator	2,600	8.6	15	1/3 HP
KF-1	KF-101	Freezer	1,700	12.4	20	1/2 HP
Glass Door* - KR-1GD		Refrigerator	3,780	13.4	20	1/2 HP

*Glass doors are not available with half doors.

Electric: 115/60/1. (220/50/1 also available, consult factory. 208-230/60/1 available for freezer only.) 9' long, 3-wire power cord with 3-prong ground-type NEMA plug.

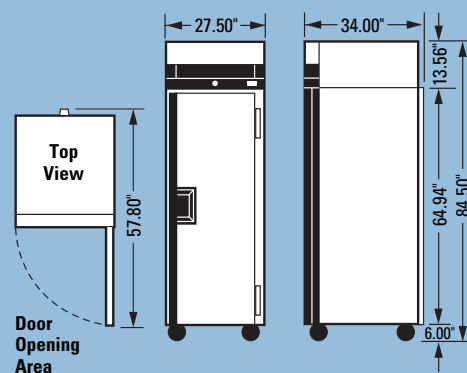

TWO-DOOR MODEL - 55" W

- Provides 49 cubic feet of gross storage capacity.
- 6 adjustable shelves
- 32.45 sq. ft. shelf area (includes floor area)

Solid Door	Half Door	Type of Unit	B.T.U per Hour	Total Amps	Max. Fuse Size	Compressor Size
KR-2	KR-201	Refrigerator	2,600	9.1	15	1/3 HP
KF-2	KF-201	Freezer	2,840	16	20	3/4 HP
Glass Door* - KR-2GD		Refrigerator	4,600	16	20	1/2 HP

*Glass doors are not available with half doors.

Electric: 115/60/1. (220/50/1 also available, consult factory. 208-230/60/1 available for freezer only.) 9' long, 3-wire power cord with 3-prong ground-type NEMA plug.

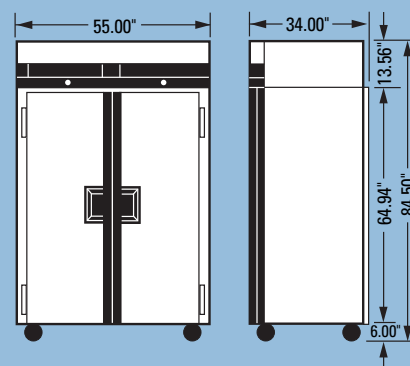

THREE-DOOR MODEL - 82.50" W

- Provides 72 cubic feet of gross storage capacity.
- 9 adjustable shelves
- 49.98 sq. ft. shelf area (includes floor area)

Solid Door	Half Door	Type of Unit	B.T.U per Hour	Total Amps	Max. Fuse Size	Compressor Size
KR-3	KR-301	Refrigerator	3,780	13.8	20	1/2 HP
KF-3	KF-301	Freezer	3,450	15.8	20	1 HP
Glass Door* - KR-3GD		Refrigerator	5,580	15.3	20	3/4 HP

*Glass doors are not available with half doors.

Electric: KR-115/60/1. KF-208-230/60/1 4-wire dual voltage required; 115 for lights and fans, 208-230 for compressor. Cord and plug not included, hard-wired by electrician.

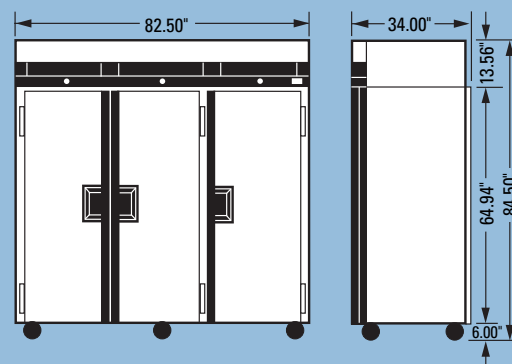

THE RIGHT CLIMATE FOR LEADERSHIP

Consult your local Manitowoc Representative:

Manitowoc Refrigeration
81 West Holly Street, P.O. Box 670 • Parsons, TN 38363, USA
Ph: 888-732-2446 • Fax: 901-847-5552
www.manitowocrefrigeration.com

A  Manitowoc Company

©2006 Manitowoc 9782B - 1/06

Continuing product improvement may necessitate change of specifications without notice.



Koolaire.